

Overview



The pressure transmitter SITRANS LH100 is a submersible sensor for hydrostatic level measurement.

The pressure transmitter measures the liquid levels in tanks, containers, channels and dams. The SITRANS LH100 pressure transmitters are available for various measuring ranges and with explosion protection as an option.

A cable box and an anchoring clamp are available as accessories for simple installation.

Benefits

- Compact design
- Simple installation
- Small error in measurement (0.3 %)
- Degree of protection IP68

Application

SITRANS LH100 pressure transmitters are used in the following branches, for example:

- Shipbuilding
- Water/waste water supply
- For use in unpressurized/open vessels and wells

Design

The pressure transmitter has a built-in ceramic sensor which is equipped with a Wheatstone resistance bridge.

These pressure transmitters are equipped with an electronic circuit fitted together with the sensor in a stainless steel enclosure. In addition, the connecting cable contains a vent pipe which is equipped with a humidity filter to prevent the build-up of condensation.

The diaphragm is protected against external influences by a protective cap.

The sensor, the electronics and the connecting cable are housed in an enclosure with small dimensions.

The pressure transmitter is temperature-compensated for a wide temperature range.

Function

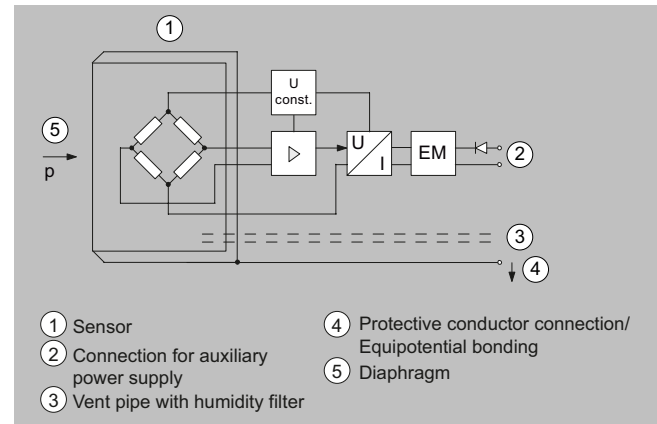

SITRANS LH100 pressure transmitter, mode of operation and connection diagram

On one side of the sensor (1), the diaphragm (5) is exposed to the hydrostatic pressure which is proportional to the submersion depth. This pressure is compared with atmospheric pressure. Pressure compensation is carried out using the vent pipe (3) in the connecting cable. The vent pipe is equipped with a humidity filter which prevents the build-up of condensation in the vent pipe.

The hydrostatic pressure of the liquid column acts on the diaphragm of the sensor and transmits the pressure to the Wheatstone resistance bridge in the sensor.

The output voltage signal of the sensor is applied to the electronic circuit where it is converted into an output current signal of 4 to 20 mA.

The protective conductor connection/equipotential bonding (4) is connected to the enclosure.

Pressure measurement

Pressure transmitters

Single-range transmitters / SITRANS LH100

Integration

It is generally recommended that the connecting cable of the SITRANS LH100 transmitter is connected to the cable box, which can be ordered separately, and secured with the anchoring clamp, also available separately. The cable box has to be installed near the measuring point.

If the medium is anything other than water, it is also necessary to check compatibility with the specified materials of the transmitter.

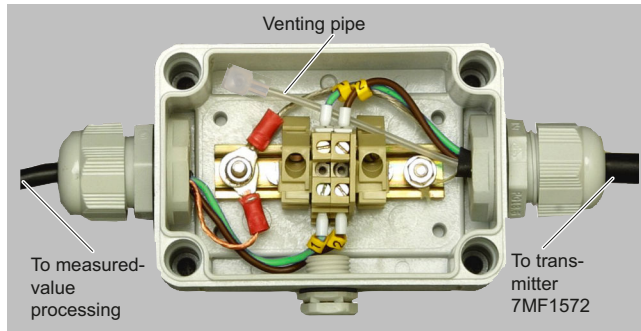

Cable box 7MF1572-8AA, open, schematic diagram



Measuring point setup, generally with cable box 7MF1572-8AA and 7MF1572-8AB cable hanger

Selection and ordering data

SITRANS LH100 pressure transmitter		Article No.	Order code
		7MF1572-	• • A • • • • •
For the measurement of the hydrostatic fill level through submersion 2-wire system, 4 ... 20 mA, enclosure material mat. no. 1.4404 (316 L) Measuring cell Al ₂ O ₃ ceramic, with permanently mounted PE cable			
Click the article number for online configuration in the PIA Life Cycle Portal.			
Measuring range	Cable length		
0 ... 3 mH ₂ O	10 m (≈ 30 ft)	1 C	
0 ... 4 mH ₂ O	10 m (≈ 30 ft)	1 D	
0 ... 5 mH ₂ O	10 m (≈ 30 ft)	1 E	
0 ... 6 mH ₂ O	10 m (≈ 30 ft)	1 F	
0 ... 10 mH ₂ O	20 m (≈ 60 ft)	1 H	
0 ... 20 mH ₂ O	30 m (≈ 90 ft)	1 K	
0 ... 9 ftH ₂ O ¹⁾	33 ft	2 C	
0 ... 12 ftH ₂ O	33 ft	2 D	
0 ... 15 ftH ₂ O	33 ft	2 E	
0 ... 18 ftH ₂ O	33 ft	2 F	
0 ... 30 ftH ₂ O	66 ft	2 H	
0 ... 60 ftH ₂ O	98 ft	2 K	
0 ... 0.3 bar ¹⁾	10 m (≈ 30 ft)	3 C	
0 ... 0.4 bar	10 m (≈ 30 ft)	3 D	
0 ... 0.5 bar	10 m (≈ 30 ft)	3 E	
0 ... 0.6 bar	10 m (≈ 30 ft)	3 F	
0 ... 1 bar	20 m (≈ 60 ft)	3 H	
0 ... 2 bar	30 m (≈ 90 ft)	3 K	
Special designs			
Measuring ranges for special designs between:			
• 0 ... 3 mH ₂ O and 0 ... 30 mH ₂ O			
• 0 ... 9 ftH ₂ O and 0 ... 100 ftH ₂ O			
• 0 ... 0.3 bar and 0 ... 3 bar			
Special cable length/special measuring range			
Add "Z" to article number, specify order code and plain text.		9 A	H . .
Note: Specification of the measuring range Y01 is mandatory!			+ Y 0 1
The following applies to determining the maximum cable length for Ex versions: Transmitters:			
• C _i = 0 µF, L _i = 0 µH			
Cables:			
• C _k = 0.19 nF per meter cable			
• L _k = 1.5 µH per meter cable			
The max. permissible data of the transmitter infeed device must be taken into account!			
3 m (10 ft)			H 1 A
5 m (16 ft)			H 1 B
7 m (23 ft)			H 1 C
10 m (33 ft)			H 1 D
15 m (49 ft)			H 1 E
20 m (66 ft)			H 1 F
25 m (82 ft)			H 1 G
30 m (98 ft)			H 1 H
40 m (131 ft)			H 1 J
50 m (164 ft)			H 1 K
60 m (198 ft)			H 1 L
70 m (231 ft)			H 1 M
80 m (264 ft)			H 1 N
90 m (297 ft)			H 1 P
100 m (330 ft)			H 1 Q
Gasket material between sensor and enclosure			
FPM (standard)		1	
EPDM (for drinking water applications)		2	
Explosion protection			
None		0	
With explosion protection ATEX II 1 G Ex ia IIC T4 Ga and IECEx Ex ia IIC T4 Ga		1	

Pressure measurement

Pressure transmitters

Single-range transmitters / SITRANS LH100

Selection and ordering data (continued)

Options	Order code
Add "-Z" to article number and specify order code.	
Quality inspection certificate (5-point characteristic curve test) according to IEC 62828-2	C11
Specification of measuring range (only with special cable lengths) in: "... to ... mH ₂ O" or "... to ... ftH ₂ O" or "... to ... bar"	Y01

Accessories/spare parts

	Article No.
Cable plug for connecting the transmitter cable	7MF1572-8AA
Anchoring clamp For mounting the pressure transmitter	7MF1572-8AB
Protective caps As a replacement (pack of 10)	7MF1572-8AD
Humidity filter As a replacement (pack of 10)	7MF1572-8AE

Technical specifications

Pressure transmitter SITRANS LH100 (submersible sensor)	
Mode of operation	
Measuring principle	Piezo-resistive
Input	
Measured variable	Hydrostatic level
Measuring range	Max. permissible operating pressure
• 0 ... 3 mH ₂ O (0 ... 9 ftH ₂ O)	• 1.5 bar (21.8 psi) (corresponds to 15 mH ₂ O (45 ftH ₂ O))
• 0 ... 4 mH ₂ O (0 ... 12 ftH ₂ O)	• 1.5 bar (21.8 psi) (corresponds to 15 mH ₂ O (45 ftH ₂ O))
• 0 ... 5 mH ₂ O (0 ... 15 ftH ₂ O)	• 1.5 bar (21.8 psi) (corresponds to 15 mH ₂ O (45 ftH ₂ O))
• 0 ... 6 mH ₂ O (0 ... 18 ftH ₂ O)	• 1.5 bar (21.8 psi) (corresponds to 15 mH ₂ O (45 ftH ₂ O))
• 0 ... 10 mH ₂ O (0 ... 30 ftH ₂ O)	• 3.0 bar (43.5 psi) (corresponds to 30 mH ₂ O (90 ftH ₂ O))
• 0 ... 20 mH ₂ O (0 ... 60 ftH ₂ O)	• 5.0 bar (72.5 psi) (corresponds to 50 mH ₂ O (150 ftH ₂ O))
• 0 ... 0.3 bar	• 1.5 bar
• 0 ... 0.4 bar	• 1.5 bar
• 0 ... 0.5 bar	• 1.5 bar
• 0 ... 0.6 bar	• 1.5 bar
• 0 ... 1 bar	• 3.0 bar
• 0 ... 2 bar	• 5.0 bar
Output	
Output signal	4 ... 20 mA
Measuring accuracy	According to IEC 62828-1
Measurement deviation at limit setting including hysteresis and reproducibility	
Measuring range	
• 0 ... 3 mH ₂ O (0 ... 9 ftH ₂ O or 0 ... 0.3 bar)	• 0.5% measuring range end value (typical) • 1.0% of measuring range end value (maximum)
• For all other measuring ranges	• 0.3% of measuring range end value (typical) • 0.6% of measuring range end value (maximum)
Effect of ambient temperature	
Measuring range	Zero and span
• 3 mH ₂ O (9 ftH ₂ O or 0.3 bar)	0.45%/10 K of measuring range end value
• 4 ... 6 mH ₂ O (12 ... 18 ftH ₂ O or 0.4...0.6 bar)	0.45%/10 K of measuring range end value
• > 6 mH ₂ O (> 18 ftH ₂ O or > 0.6 bar)	0.3%/10 K of measuring range end value
Long-term stability	
Measuring range	Zero and span
• 3 mH ₂ O (9 ftH ₂ O or 0.3 bar)	0.4% of measuring range end value/year
• 4 ... 6 mH ₂ O (12 ... 18 ftH ₂ O or 0.4...0.6 bar)	0.25% of measuring range end value/year
• > 6 mH ₂ O (> 18 ftH ₂ O or > 0.6 bar)	0.2% of measuring range end value/year
Operating conditions	
Ambient conditions	
• Process temperature	-10 ... +80 °C (14 ... 176 °F)
• Storage temperature	-40 ... +80 °C (-40 ... +176 °F)
Degree of protection according to IEC 60529	IP68
Structural design	
Weight	
• Pressure transmitter	≈ 0.2 kg (≈ 0.44 lb)

Technical specifications (continued)

Pressure transmitter SITRANS LH100 (submersible sensor)	
• Cable; maximum cable length 100 m (330 ft)	0.025 kg/m (≈ 0.015 lb/ft)
Electrical connection	Cable with 3 conductors, vent pipe and integrated humidity filter
Material	
• Seal diaphragm	Al ₂ O ₃ ceramic, 96%
• Enclosure	Stainless steel, mat. no. 1.4404/316L
• Gasket	• FPM (standard) • EPDM (optional)
• Connecting cable	• PE-HD (standard) • PE-LD (in the case of versions with EPDM seal, suitable for drinking water applications)
Auxiliary power	
Terminal voltage on pressure transmitter U _B	• 10 ... 33 V DC • 10 ... 30 V DC for transmitter with intrinsic safety explosion protection
Certificates and approvals	
Drinking water approval (ACS)	15 ACC NY 360
EAC	№ TC RU C-DE.ГБ05.В.00732 OC НАННО «ЦСБЭ»
Underwriters Laboratories (UL)	2014-11-17 - E344532
The device is not subject to the pressure equipment directive (PED 2014/68/EU)	
Explosion protection	
• Intrinsic safety "i"	IECEx SEV 14.0003 SEV 14 ATEX 0109
- Marking	II 1 G Ex ia IIC T4 Ga
• EAC Ex	TC RU C-DE.AA87.B.00324

Cable box

Cable box	
Area of application	For connecting the transmitter cable
Structural design	
Weight	0.2 kg (0.44 lb)
Electrical connection	2 x 3-way (28 to 18 AWG)
Cable entry	2 x Pg 9
Enclosure material	Polycarbonate
Vent valve for atmospheric pressure	
Operating conditions	
Degree of protection according to IEC 60529	IP65

Anchoring clamp

Anchoring clamp	
Area of application	For mounting the transmitter
Structural design	
Weight	0.16 kg (0.35 lb)
Material	Zinc-plated steel, polyamide

Pressure measurement

Pressure transmitters

Single-range transmitters / SITRANS LH100

Dimensional drawings

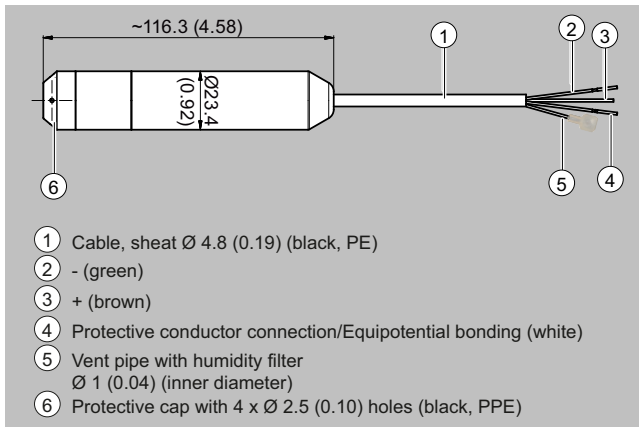

SITRANS LH100 pressure transmitter, dimensions in mm (inch)

Dimensional drawings (continued)

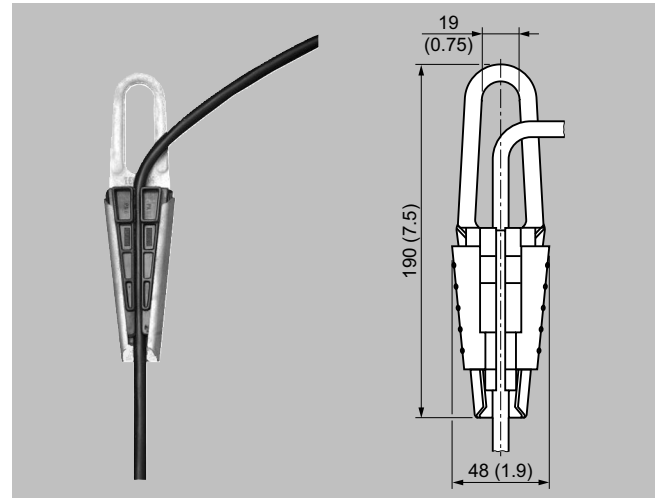

Anchoring clamp, dimensions in mm (inch)

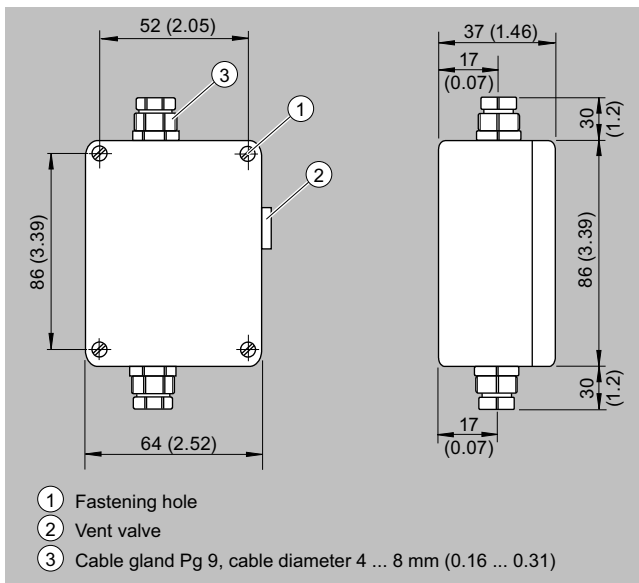

Junction box, dimensions in mm (inch)

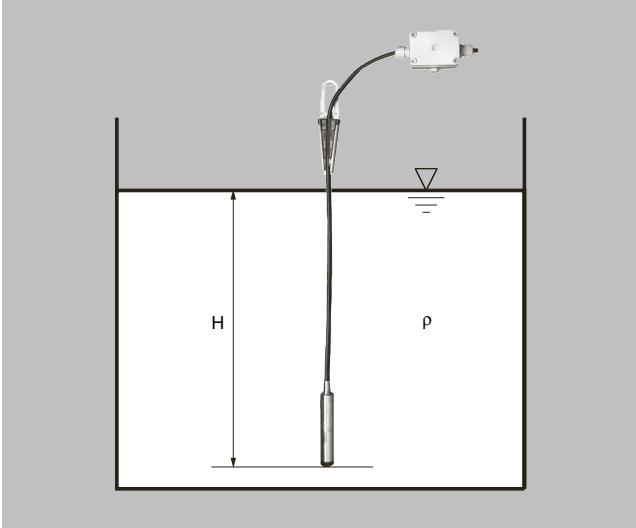
More information**Establishing the measuring range with water as process medium**Calculation of the measuring range

$$p = \rho \times g \times H$$

with:

 ρ = density of medium g = local gravitational acceleration H = maximum levelExample:Medium: Water, $\rho = 1\,000\text{ kg/m}^3$ Gravitational acceleration: 9.81 m/s^2

Lower range value: 0 m

Maximum level: 6.0 m

Cable length: 10 m

Calculation:

$$p = 1\,000\text{ kg/m}^3 \times 9.81\text{ m/s}^2 \times 6.0\text{ m}$$

$$p = 58\,860\text{ N/m}^2$$

$$p = 589\text{ mbar}$$

Transmitter to be ordered:

7MF1572-1FA10

Plus, if required, cable box 7MF1572-8AA and anchoring clamp

7MF1572-8AB

Pressure measurement

Pressure transmitters

Single-range transmitters / SITRANS LH300

Overview

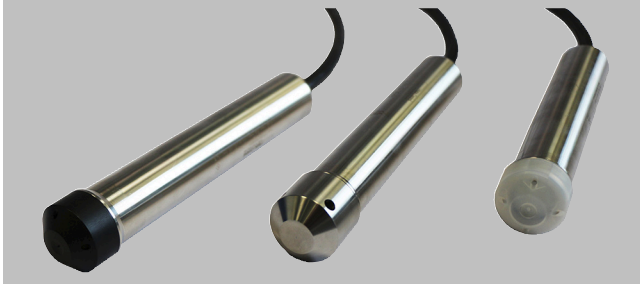

The pressure transmitter SITRANS LH300 is a submersible sensor for hydrostatic level measurement with a protective capability made of PPE (left), stainless steel (center) and ETFE (right).

The pressure transmitter measures the liquid levels in tanks, containers, channels and dams. The SITRANS LH300 pressure transmitters are available for various measuring ranges and with explosion protection as an option.

A cable box and an anchoring clamp are available as accessories for simple installation.

Benefits

- Compact design
- Simple installation
- Small error in measurement (typically 0.15%)
- Degree of protection IP68

Application

SITRANS LH300 pressure transmitters are used in the following fields of industry, for example:

- Shipbuilding
- Water/waste water supply
- Drinking water treatment plants
- For use in unpressurized/open vessels and wells
- Desalination plants

Design

The pressure transmitter has a built-in ceramic sensor which is equipped with a Wheatstone resistance bridge.

These pressure transmitters are equipped with an electronic circuit fitted together with the sensor in a stainless steel enclosure. In addition, the connecting cable contains a vent pipe which is equipped with a humidity filter to prevent the build-up of condensation.

The diaphragm is protected against external influences by a protective cap.

The sensor, the electronics and the connecting cable are housed in an enclosure with small dimensions.

The pressure transmitter is temperature-compensated for a wide temperature range.

Function

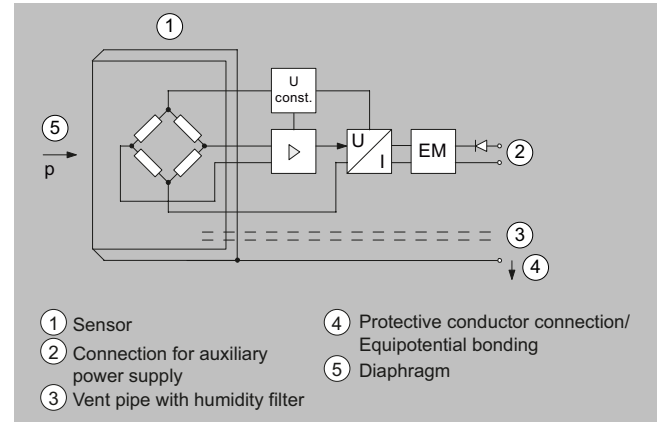

SITRANS LH300 pressure transmitter, mode of operation and connection diagram

On one side of the sensor (1), the diaphragm (5) is exposed to the hydrostatic pressure which is proportional to the submersion depth. This pressure is compared with atmospheric pressure. Pressure compensation is carried out using the vent pipe (3) in the connecting cable. The vent pipe is equipped with a humidity filter which prevents the build-up of condensation in the vent pipe.

The hydrostatic pressure of the liquid column acts on the diaphragm of the sensor and transmits the pressure to the Wheatstone resistance bridge in the sensor.

The output voltage signal of the sensor is applied to the electronic circuit where it is converted into an output current signal of 4 to 20 mA.

The protective conductor connection/equipotential bonding (4) is connected to the enclosure.

Integration

It is generally recommended that the connecting cable of the SITRANS LH300 transmitter is connected to the cable box, which can be ordered separately, and secured with an anchoring clamp, also available separately. The cable box is to be installed near the measuring point, but outside the process medium.

Likewise, in the case of process media other than water, the compatibility with the specified materials of the transmitter, cable and seal must be checked.

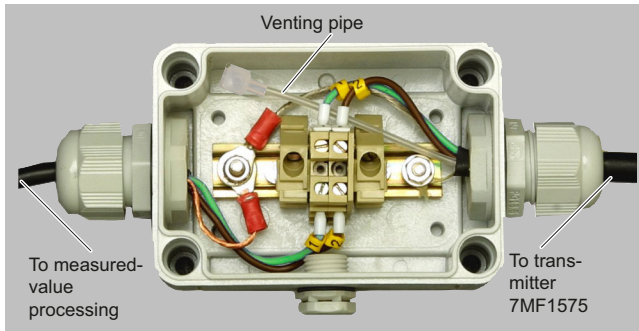

Cable box 7MF1575-8AA, opened, schematic representation



Measurement location setup, in principle with cable box 7MF1575-8AA and anchoring clamp 7MF1575-8AB

Pressure measurement

Pressure transmitters

Single-range transmitters / SITRANS LH300

Selection and ordering data

SITRANS LH300 pressure transmitter		Article No. 7MF1575-	Order code
For the measurement of the hydrostatic level, immersion probe, 2-wire system, 4 ... 20 mA, for enclosure material see ordering option, measuring cell Al ₂ O ₃ ceramic (99.6% purity), with permanently mounted cable. Material of protective cap for PE cable: PPE (color: black). Material of protective cap for FEP cable: PPE (color: white). <u>Note:</u> Cable box and cable hanger must be ordered separately.		● ● ● ● ● ● ● ●	
Click the article number for online configuration in the PIA Life Cycle Portal.			
Measuring range	Cable length (PE cable)		
0 ... 1 mH ₂ O	5 m (≈ 15 ft)	1 A	
0 ... 2 mH ₂ O	5 m (≈ 15 ft)	1 B	
0 ... 3 mH ₂ O	10 m (≈ 30 ft)	1 C	
0 ... 4 mH ₂ O	10 m (≈ 30 ft)	1 D	
0 ... 5 mH ₂ O	10 m (≈ 30 ft)	1 E	
0 ... 6 mH ₂ O	10 m (≈ 30 ft)	1 F	
0 ... 10 mH ₂ O	20 m (≈ 60 ft)	1 H	
0 ... 20 mH ₂ O	30 m (≈ 90 ft)	1 K	
0 ... 40 mH ₂ O	50 m (≈ 150 ft)	1 L	
0 ... 3 ftH ₂ O	5 m (≈ 15 ft)	2 A	
0 ... 6 ftH ₂ O	5 m (≈ 15 ft)	2 B	
0 ... 9 ftH ₂ O	10 m (≈ 30 ft)	2 C	
0 ... 12 ftH ₂ O	10 m (≈ 30 ft)	2 D	
0 ... 15 ftH ₂ O	10 m (≈ 30 ft)	2 E	
0 ... 18 ftH ₂ O	10 m (≈ 30 ft)	2 F	
0 ... 30 ftH ₂ O	20 m (≈ 60 ft)	2 H	
0 ... 60 ftH ₂ O	30 m (≈ 90 ft)	2 K	
0 ... 120 ftH ₂ O	50 m (≈ 150 ft)	2 L	
0 ... 0.1 bar	5 m (≈ 15 ft)	3 A	
0 ... 0.2 bar	5 m (≈ 15 ft)	3 B	
0 ... 0.3 bar	10 m (≈ 30 ft)	3 C	
0 ... 0.4 bar	10 m (≈ 30 ft)	3 D	
0 ... 0.5 bar	10 m (≈ 30 ft)	3 E	
0 ... 0.6 bar	10 m (≈ 30 ft)	3 F	
0 ... 1 bar	20 m (≈ 60 ft)	3 H	
0 ... 2 bar	30 m (≈ 90 ft)	3 K	
0 ... 4 bar	50 m (≈ 150 ft)	3 L	
Special designs			
Measuring ranges for special designs between:			
0 ... 1 mH ₂ O and 0 ... 160 mH ₂ O or			
0 ... 3 ftH ₂ O and 0 ... 530 ftH ₂ O or			
0 ... 0.1 bar and 0 ... 16 bar possible.			
PE cable for general applications and drinking water applications			
Special cable length		9 X	H . .
Add "-Z" to article number, specify order code and plain text:			
Y01: Cable length			
3 m (≈ 10 ft)			H 1 A
5 m (≈ 16 ft)			H 1 B
7 m (≈ 23 ft)			H 1 C
10 m (≈ 33 ft)			H 1 D
15 m (≈ 50 ft)			H 1 E
20 m (≈ 65 ft)			H 1 F
25 m (≈ 80 ft)			H 1 G
30 m (≈ 100 ft)			H 1 H
40 m (≈ 130 ft)			H 1 J
50 m (≈ 160 ft)			H 1 K
60 m (≈ 200 ft)			H 1 L
70 m (≈ 230 ft)			H 1 M
80 m (≈ 265 ft)			H 1 N
90 m (≈ 295 ft)			H 1 P
100 m (≈ 330 ft)			H 1 Q
125 m (≈ 410 ft)			H 1 R
150 m (≈ 495 ft)			H 1 S

Selection and ordering data (continued)

SITRANS LH300 pressure transmitter	Article No.					Order code		
	7	M	F	1	5	7	5	7
175 m (≈ 575 ft)								H 1 T
200 m (≈ 650 ft)								H 1 U
225 m (≈ 740 ft)								H 1 V
250 m (≈ 820 ft)								H 1 W
275 m (≈ 900 ft)								H 1 X
300 m (≈ 990 ft)								H 2 A
350 m (≈ 1150 ft)								H 2 B
400 m (≈ 1320 ft)								H 2 C
450 m (≈ 1480 ft)								H 2 D
500 m (≈ 1650 ft)								H 2 E
550 m (≈ 1815 ft)								H 2 F
600 m (≈ 1980 ft)								H 2 G
650 m (≈ 2145 ft)								H 2 H
700 m (≈ 2310 ft)								H 2 J
750 m (≈ 2475 ft)								H 2 K
800 m (≈ 2640 ft)								H 2 L
850 m (≈ 2800 ft)								H 2 M
900 m (≈ 2970 ft)								H 2 N
950 m (≈ 3135 ft)								H 2 P
1 000 m (≈ 3300 ft)								H 2 Q
Additional special cable lengths	9	X						H 1 Y
Add "Z" to article number, specify order code and plain text: H1Y: Cable length								+
Y01: Measuring range								Y 0 1
FEP cable for corrosive process media								
Special cable length	9	X						H . .
Add "Z" to article number, specify order code and plain text: Y01: Cable length								+
								Y 0 1
3 m (≈ 10 ft)								H 5 A
5 m (≈ 16 ft)								H 5 B
7 m (≈ 23 ft)								H 5 C
10 m (≈ 33 ft)								H 5 D
15 m (≈ 50 ft)								H 5 E
20 m (≈ 65 ft)								H 5 F
25 m (≈ 80 ft)								H 5 G
30 m (≈ 100 ft)								H 5 H
40 m (≈ 130 ft)								H 5 J
50 m (≈ 160 ft)								H 5 K
60 m (≈ 200 ft)								H 5 L
70 m (≈ 230 ft)								H 5 M
80 m (≈ 265 ft)								H 5 N
90 m (≈ 295 ft)								H 5 P
100 m (≈ 330 ft)								H 5 Q
125 m (≈ 410 ft)								H 5 R
150 m (≈ 495 ft)								H 5 S
175 m (≈ 575 ft)								H 5 T
200 m (≈ 650 ft)								H 5 U
225 m (≈ 740 ft)								H 5 V
250 m (≈ 820 ft)								H 5 W
275 m (≈ 900 ft)								H 5 X
300 m (≈ 990 ft)								H 6 A
350 m (≈ 1150 ft)								H 6 B
400 m (≈ 1320 ft)								H 6 C
450 m (≈ 1480 ft)								H 6 D
500 m (≈ 1650 ft)								H 6 E
550 m (≈ 1815 ft)								H 6 F
600 m (≈ 1980 ft)								H 6 G

Pressure measurement

Pressure transmitters

Single-range transmitters / SITRANS LH300

Selection and ordering data (continued)

SITRANS LH300 pressure transmitter		Article No. 7MF1575-					Order code			
		●	●	●	●	●	●	●	●	
650 m (≈ 2145 ft)								H	6	H
700 m (≈ 2310 ft)								H	6	J
750 m (≈ 2475 ft)								H	6	K
800 m (≈ 2640 ft)								H	6	L
850 m (≈ 2800 ft)								H	6	M
900 m (≈ 2970 ft)								H	6	N
950 m (≈ 3135 ft)								H	6	P
1000 m (≈ 3300 ft)								H	6	Q
Additional special cable lengths		9	X					H	5	Y
Add "-Z" to article number, specify order code and plain text: H1Y: Cable length Y01: Measuring range								+		
								Y	0	1
Material of the enclosure	Protective cap material									
Stainless steel 316L (1.4404)	Protective cap made of PPE (recommended for PE cable)							A		
Stainless steel 316L (1.4404)	Protective cap made of ETFE (standard with FEP cable)							B		
Stainless steel 316L (1.4404)	Stainless steel 316L (1.4404)							C		
Stainless steel 904L (1.4539) for seawater applications	Protective cap made of PPE							D		
Stainless steel 904L (1.4539) for seawater applications	Protective cap made of ETFE							E		
Stainless steel 904L (1.4539) for seawater applications	Stainless steel 904L (1.4539) for seawater applications							F		
Gasket material between sensor and enclosure										
FPM (standard)								1		
EPDM (for drinking water applications)								2		
Explosion protection										
None								0		
With ATEX II1 G Ex ia IIC T4 Ga, IECEx Ex ia IIC T4 Ga and EAC Ex explosion protection (only possible for cable length ≤ 300 m (990 ft))								1		

Options	Order code
Quality test certificate (factory calibration) according to IEC 62828-2 (6 points upward)	C11

Accessories/spare parts

	Article No.
Cable box	7MF1575-8AA
Anchoring clamp	7MF1575-8AB
Protective cap, PPE As spare part (pack of 10)	7MF1575-8AD
Protective cap, ETFE As spare part (pack of 10)	7MF1575-8AE
Humidity filter As spare part (pack of 10)	7MF1575-8AF
Protective cap, stainless steel 316L (1.4404) For wastewater applications	7MF1575-8AG
Protective cap, stainless steel 904L (1.4539) For seawater applications	7MF1575-8AH

Technical specifications

Pressure transmitter SITRANS LH300 (submersible sensor)	
Mode of operation	
Measuring principle	Piezo-resistive
Input	
Measured variable	Hydrostatic level
Measuring range	Max. permissible operating pressure
• 0 ... 1 mH ₂ O (0 ... 3 ftH ₂ O)	• 1.5 bar (21.8 psi) (corresponds to 15 mH ₂ O (45 ftH ₂ O))
• 0 ... 2 mH ₂ O (0 ... 6 ftH ₂ O)	• 1.5 bar (21.8 psi) (corresponds to 15 mH ₂ O (45 ftH ₂ O))
• 0 ... 3 mH ₂ O (0 ... 9 ftH ₂ O)	• 1.5 bar (21.8 psi) (corresponds to 15 mH ₂ O (45 ftH ₂ O))
• 0 ... 4 mH ₂ O (0 ... 12 ftH ₂ O)	• 2 bar (29 psi) (corresponds to 20 mH ₂ O (60 ftH ₂ O))
• 0 ... 5 mH ₂ O (0 ... 15 ftH ₂ O)	• 2 bar (29 psi) (corresponds to 20 mH ₂ O (60 ftH ₂ O))
• 0 ... 6 mH ₂ O (0 ... 18 ftH ₂ O)	• 2 bar (29 psi) (corresponds to 20 mH ₂ O (60 ftH ₂ O))
• 0 ... 10 mH ₂ O (0 ... 30 ftH ₂ O)	• 5 bar (72.5 psi) (corresponds to 50 mH ₂ O (150 ftH ₂ O))
• 0 ... 20 mH ₂ O (0 ... 60 ftH ₂ O)	• 10 bar (145 psi) (corresponds to 100 mH ₂ O (300 ftH ₂ O))
• 0 ... 40 mH ₂ O (0 ... 120 ftH ₂ O)	• 20 bar (290 psi) (corresponds to 200 mH ₂ O (600 ftH ₂ O))
Special measuring ranges	
• Up to 100 mH ₂ O (0 ... 300 ftH ₂ O)	• 20 bar (290 psi) (corresponds to 200 mH ₂ O (600 ftH ₂ O))
• Up to 160 mH ₂ O (0 ... 480 ftH ₂ O)	• 24 bar (348 psi) (corresponds to 240 mH ₂ O (720 ftH ₂ O))
Measuring range	
• 0 ... 0.1 bar	• 1.5 bar
• 0 ... 0.2 bar	• 1.5 bar
• 0 ... 0.3 bar	• 1.5 bar
• 0 ... 0.4 bar	• 2 bar
• 0 ... 0.5 bar	• 2 bar
• 0 ... 0.6 bar	• 2 bar
• 0 ... 1 bar	• 5 bar
• 0 ... 2 bar	• 10 bar
• 0 ... 4 bar	• 20 bar
Special measuring ranges	
• Up to 10 bar	• 20 bar
• Up to 20 bar	• 24 bar
Output	
Output signal	4 ... 20 mA
Measuring accuracy	According to IEC 62828-1
Measurement deviation at limit setting including hysteresis and reproducibility	• ≤ 0.15% of the measuring range end value (typical) • ≤ 0.3% of the measuring range end value (max.)
Effect of ambient temperature	≤ 0.05%/10 K of the measuring range end value (zero point and span)
Long-term stability	≤ 0.15% of the measuring range end value/year (zero point and span)
Operating conditions	
Ambient conditions	
• Process temperature	-10 ... +80 °C (14 ... 176 °F)
• Storage temperature	-20 ... +80 °C (-4 ... +176 °F)
Degree of protection according to IEC 60529	IP68
Structural design	
Weight	
• Pressure transmitter	≈ 0.4 kg (≈ 0.88 lb)

Technical specifications (continued)

Pressure transmitter SITRANS LH300 (submersible sensor)	
• Cable	0.08 kg/m (≈ 0.059 lb/ft)
Maximum of freely hanging length	300 m (990 ft)
Electrical connection	Cable with 2 wires, vent pipe and integrated humidity filters
Material	
• Seal diaphragm	Al ₂ O ₃ ceramic, 96%
• Enclosure	Stainless steel, mat. no. 1.4404/316L or 1.4539/904L for seawater applications
• Gasket	• FPM (standard) • EPDM (optional)
• Connecting cable	• PE (standard/drinking water applications) • FEP (for corrosive process media)
• Protective cap	Stainless steel, PPE or ETFE
Auxiliary power	
Terminal voltage on pressure transmitter U _B	• 10 ... 33 V DC for transmitter without explosion protection • 10 ... 30 V DC for transmitter with intrinsic safety explosion protection
Certificates and approvals	
Drinking water approval (ACS)	17 ACC NY 055
EAC	TC N RU Д-DE.ΓA02.B.05092
Underwriters Laboratories (UL)	ML File No. E344532, issued 2017-08-17
Marine approval (LR)	LR_18/20074
Marine approval (DNV/GL)	TAA00000CE
Marine approval (BV)	56926/A0 BV
Marine approval (ABS)	HG1881314_P
Marine approval (RINA)	ELE067319XG
Pressure Equipment Directive	The transmitter is not subject to the pressure equipment directive (DGRL 2014/68/EU)
Explosion protection	
• ATEX	SEV 16 ATEX 0121
• IEC Ex	IEC Ex SEV 16.0003
• EAC Ex	TC RU C-DE.AA87.B.00324
Intrinsic safety "i"	
• Marking	II 1 G Ex ia IIC T4 Ga

Cable box

Area of application	For connecting the transmitter cable
Structural design	
Weight	0.2 kg (0.44 lb)
Electrical connection	2 x 3-way (28 to 18 AWG)
Cable entry	2 x PG 13.5
Enclosure material	Polycarbonate
Vent valve for atmospheric pressure	
Operating conditions	
Degree of protection according to IEC 60529	IP65

Anchoring clamp

Area of application	For mounting the transmitter
Structural design	
Weight	0.16 kg (0.35 lb)
Material	Zinc-plated steel, polyamide
Terminal area	For cable with a diameter of 5.5 ... 9.5 mm

Pressure measurement

Pressure transmitters

Single-range transmitters / SITRANS LH300

Dimensional drawings

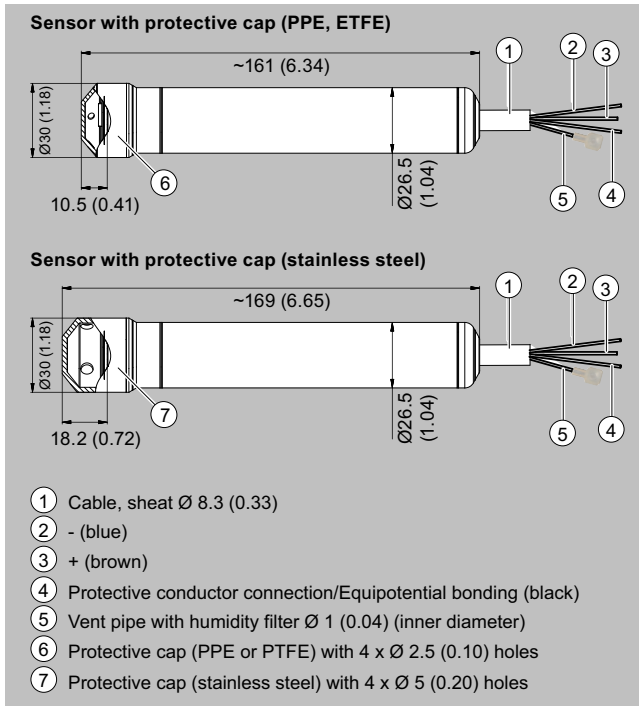

SITRANS LH300 pressure transmitter, dimensions in mm (inch)

Dimensional drawings (continued)

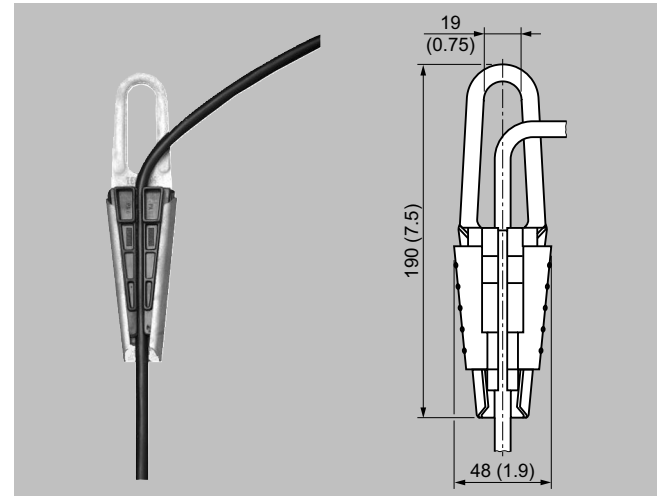

Anchoring clamp, dimensions in mm (inch)

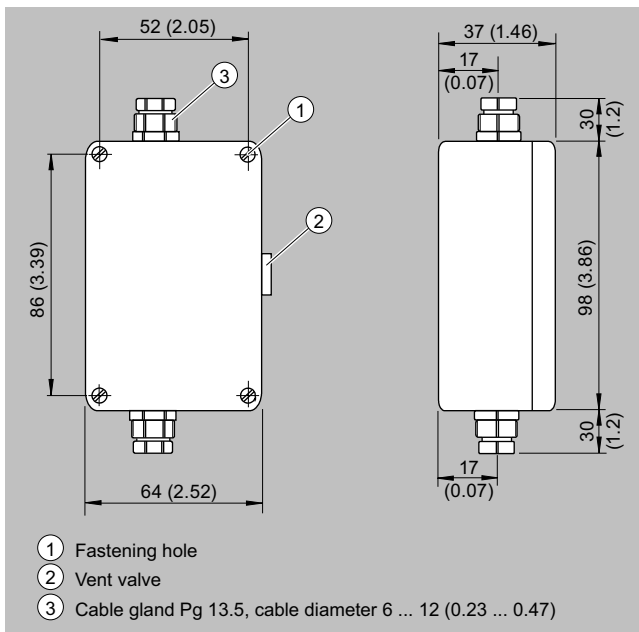

Cable box, dimensions in mm (inch)

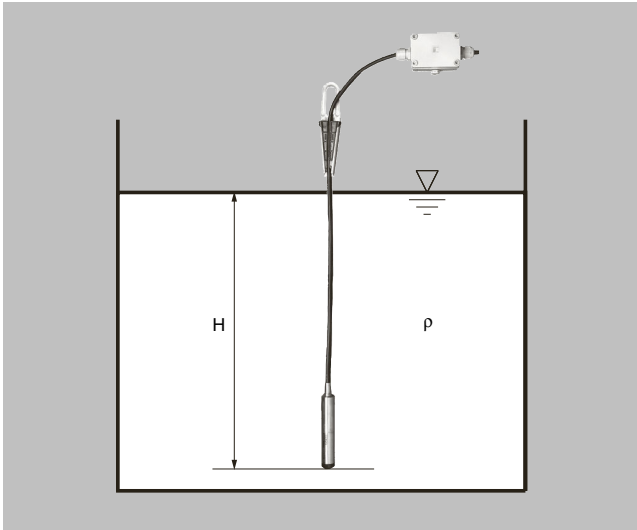
More information**Determination of the measuring range for water as process medium**

Calculation of the measuring range:

$$p = \rho \times g \times H$$

with:

ρ = density of medium

g = local gravitational acceleration

H = maximum level

Example:

Medium: Water, $\rho = 1\,000\text{ kg/m}^3$

Gravitational acceleration: 9.81 m/s^2

Lower range value: 0 m

Maximum level: 6.0 m

Cable length: 10 m

Calculation:

$$p = 1\,000\text{ kg/m}^3 \times 9.81\text{ m/s}^2 \times 6.0\text{ m}$$

$$p = 58\,860\text{ N/m}^2$$

$$p = 589\text{ mbar}$$

Transmitter to be ordered:

7MF1575-1FA10

Plus, if required, cable box 7MF1575-8AA and anchoring clamp

7MF1575-8AB